

LEAP CONNECT

Practice Test Reference Materials

English Language Arts
Grade 5

Practice Test Reference Materials and Writing Stimuli include required graphics that are to be presented to the student during the administration of LEAP Connect ELA Practice Test. Refer to the *Directions for Practice Test Administration* (DPTA) for detailed instructions.

Session 1

“Changes for Johnny and Debbie” Answer Options (Items 1 – 5)

“Train Garden”/ “Paul Busse, Train Garden Designer” Answer Options (Items 6 – 11)

“Camping with Confidence” Answer Options (Items 12 – 19)

Session 2

“Master P and Malakai” Answer Options (Items 20 – 24)

Session 3

Answer Options (Items 25 – 28)

Writing Stimulus 1, “Janell’s Cake” (Items 29 – 32)

Answer Options (Items 29 – 32)

Session 4

Writing Stimulus 2, “Easy to Be Kind” (Cards 1a – 10a)

Session 1

Session 1 – Item 1 Answer Options



A. Debbie finishes high school.



B. Debbie gets a new job.

Session 1 – Item 2 Answer Options

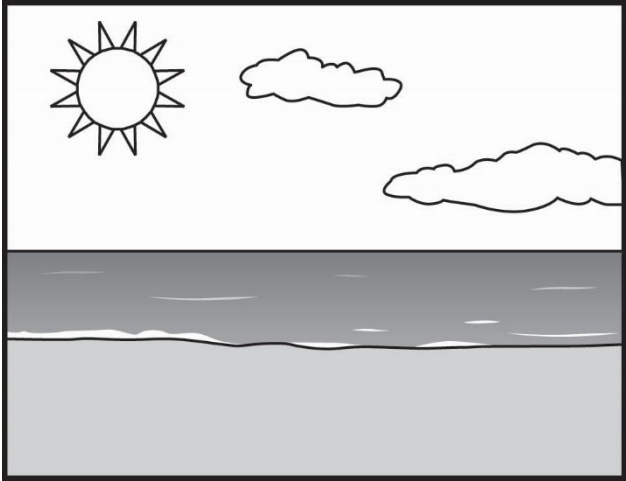

A. the beach

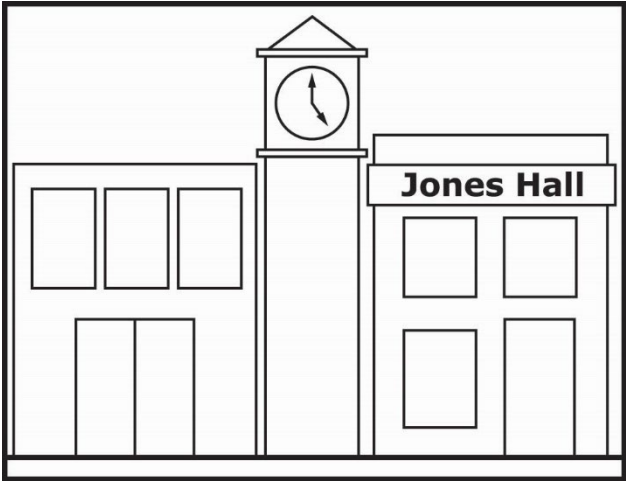

B. to college

Session 1 – Item 3 Answer Options

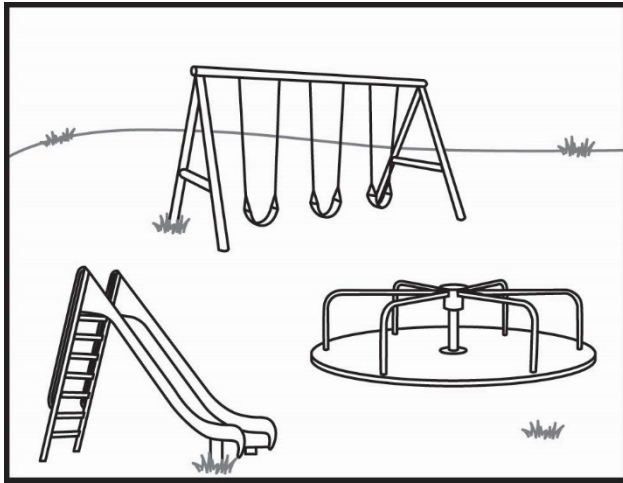

A. a playground



B. a tree

Session 1 – Item 4 Answer Options

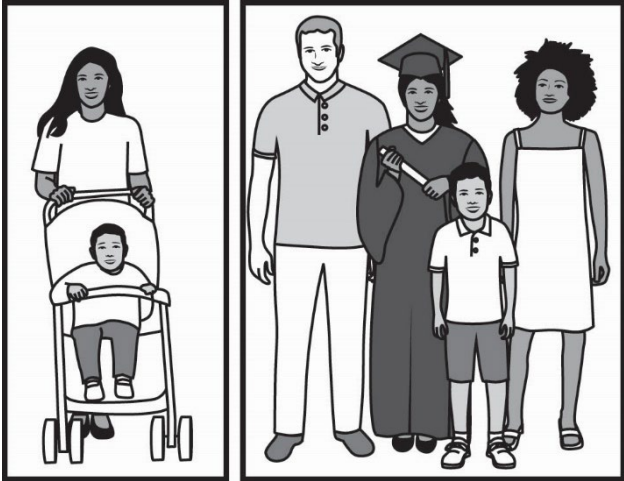

A. pictures

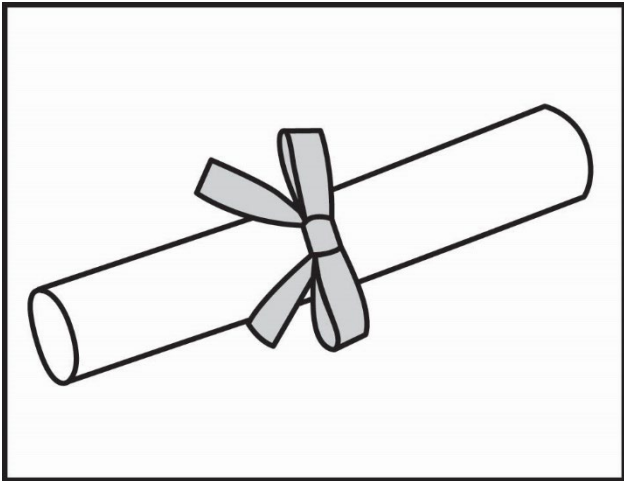

B. her diploma

Session 1 – Item 5 Answer Options

A.

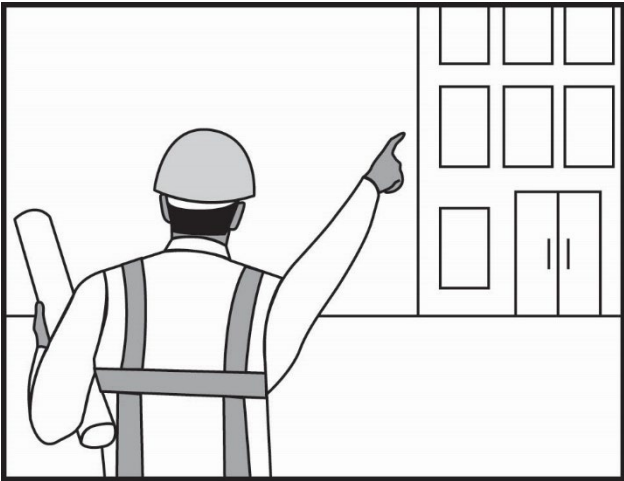

B.



Session 1 – Item 6 Answer Options

- A. Both describe having model trains in gardens.

- B. Both show what causes model trains to break down.

- C. Both tell about someone who showed his train garden at a state fair.

Session 1 – Item 7 Answer Options

- A. Only one provides the steps to build a model train from scratch.

- B. Only one compares the train garden to real trains and buildings.

- C. Only one describes ways to set up a train garden in a city.

Session 1 – Item 8 Answer Options



- A. The train garden has model trains and buildings that look like a small city.



- B. The model buildings are painted many different colors.



C. The model trains are made by people in a factory.

Session 1 – Item 9 Answer Options



A. "They look like toy trains."



B. "The model trains are made with strong plastic."

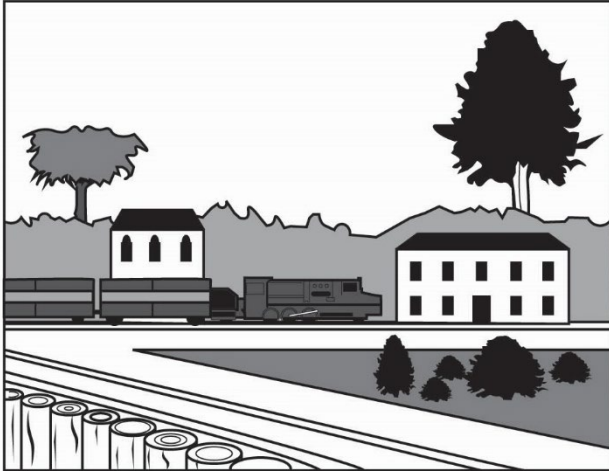

- C. "The train garden looks like New Orleans did many years ago."

Session 1 – Item 10 Answer Options



A. The garden has model trains and buildings.



B. Many people have seen flower gardens.



C. The train garden is hard to care for.

Session 1 – Item 11 Answer Options

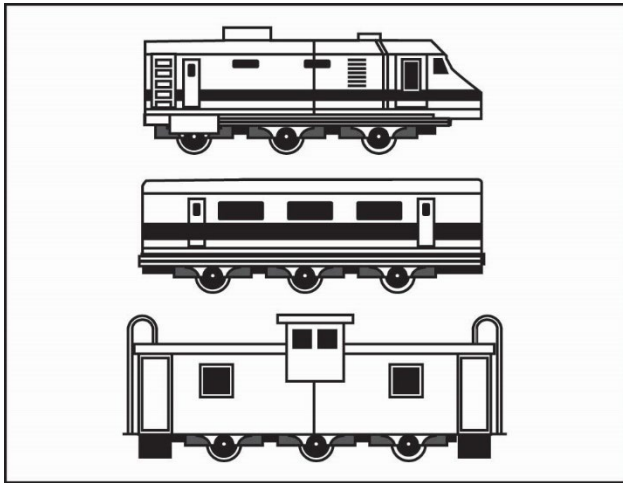

A. The model trains have different designs.

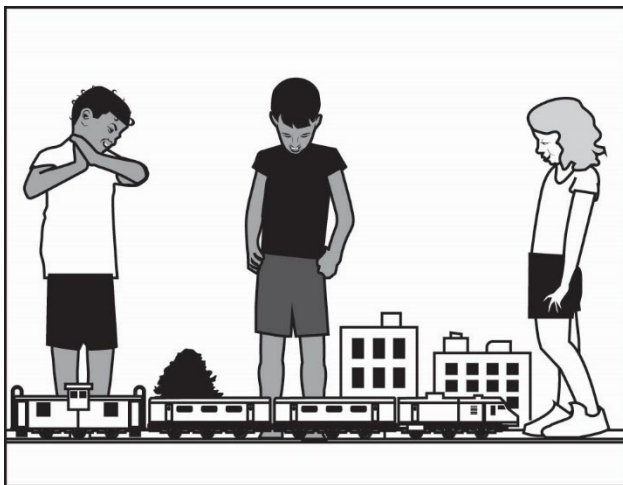

B. The model trains and buildings are very small.

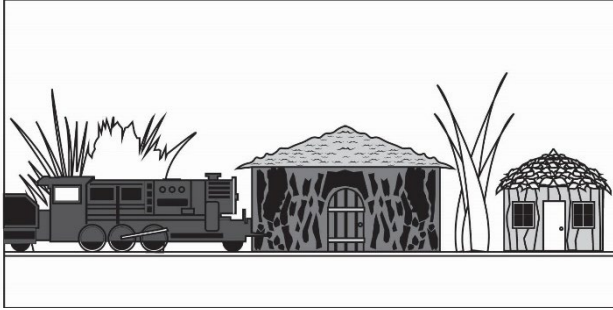

- C. The gardens contain trains and buildings made from natural materials.

Session 1 – Item 12 Answer Options

- A. Finn meets Rob, his camp counselor.
- B. Finn improves with practice and patience.
- C. Finn learns about different sports, like soccer.

Session 1 – Item 13 Answer Options

- A. Rob announces his group of campers for the week.

- B. Rob meets his group of campers at the bus when they arrive.

- C. Rob teaches his group of campers new games and sports to play.

Session 1 – Item 14 Answer Options

- A. Finn decides to trust Rob, even though he is afraid.

- B. Finn tries new activities, even karate and horseback riding.

- C. Finn gains confidence to try new things, even when they are hard.

Session 1 – Item 15 Answer Options

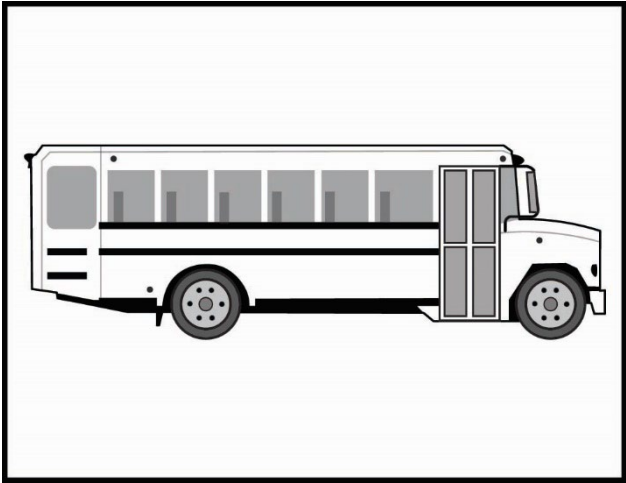

A. a bus

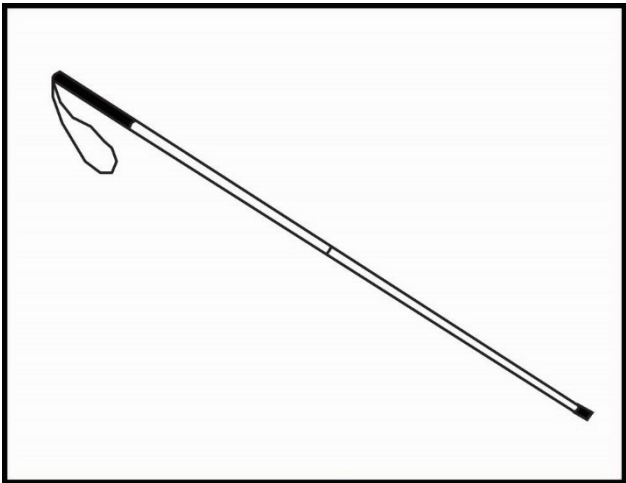

B. a cane



C. a driver

Session 1 – Item 16 Answer Options

A. He does not play many sports.

B. He has never been to camp before.

C. He has not stayed in a cabin for five days.

Session 1 – Item 17 Answer Options

- A. Both Finn and Rob are excited.

- B. Both Finn and Rob are nervous.

- C. Finn is nervous and Rob is excited.

Session 1 – Item 18 Answer Options

A. They listen and then they understand.

B. They practice and then they improve.

C. They learn and then they help others.

Session 1 – Item 19 Answer Options

A. camps in a tent alone

B. wins a game after practicing

C. shows others how to do something

Session 2

Session 2 – Item 20 Answer Options



A. Master P and Malakai wrote a book together.



B. Master P is from New Orleans, Louisiana.



C. Malakai is learning to read braille.

Session 2 – Item 21 Answer Options

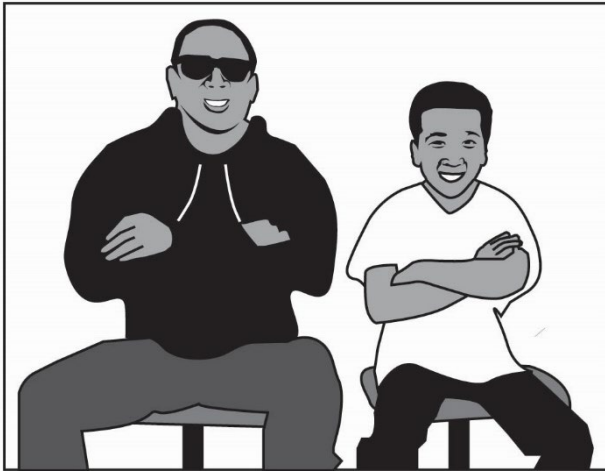

A. Master P is older than Malakai.

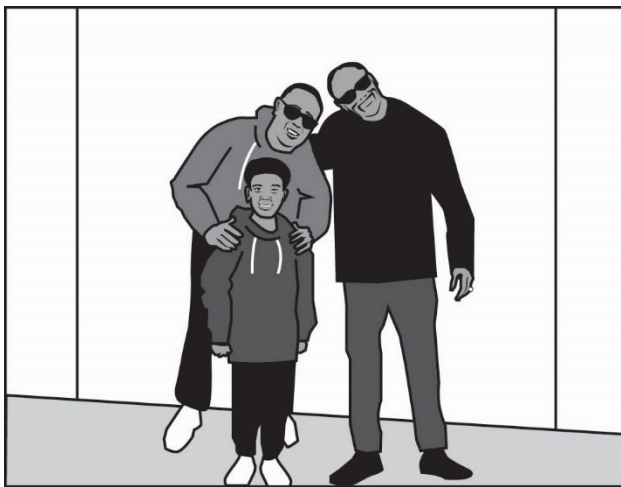

B. Master P thought people would like to hear Malakai's story.

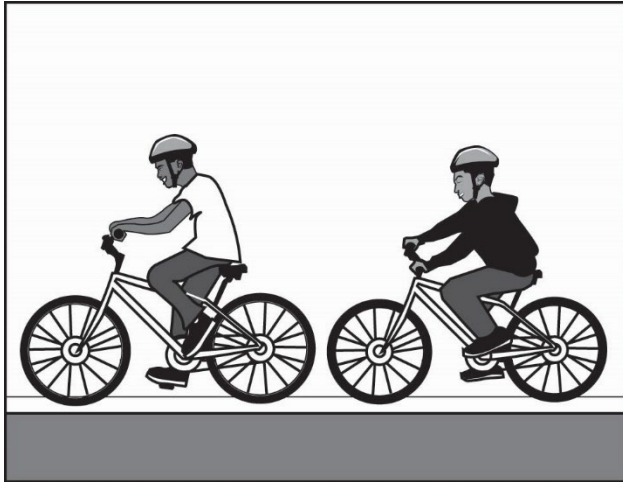

C. He rides his bicycle and has adventures just like Malakai.

Session 2 – Item 22 Answer Options



A. Since writing his book, Malakai has joined groups that support young people.

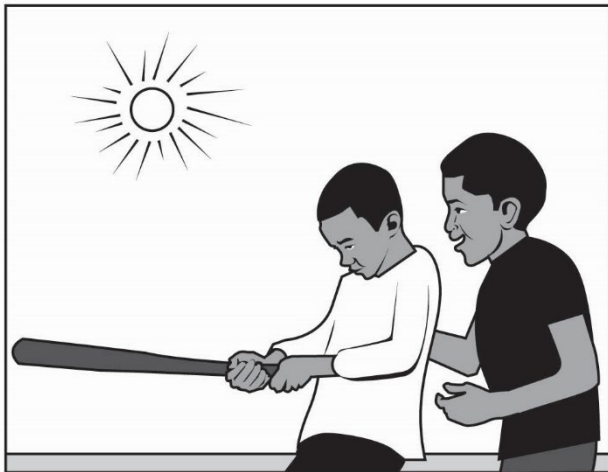

B. Malakai plays baseball with a friend.

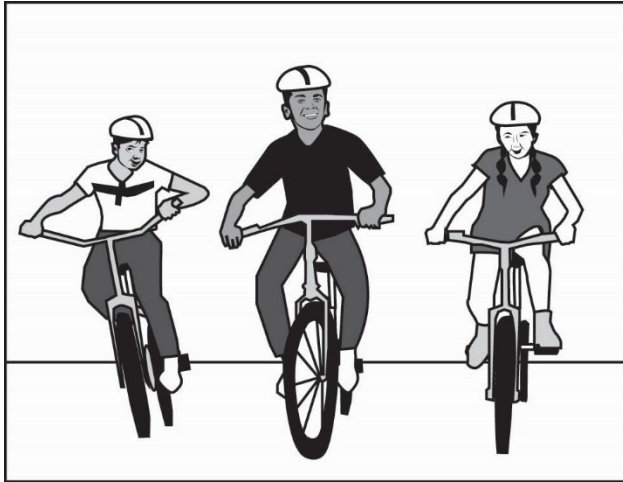

C. Malakai rides his bike and has adventures.

Session 2 – Item 23 Answer Options



A. Master P and Malakai are still friends.



B. Malakai goes to a school with other students who are blind.



C. Malakai rides his bike and has adventures just like the Malakai in the book.

Session 2 – Item 24 Answer Options

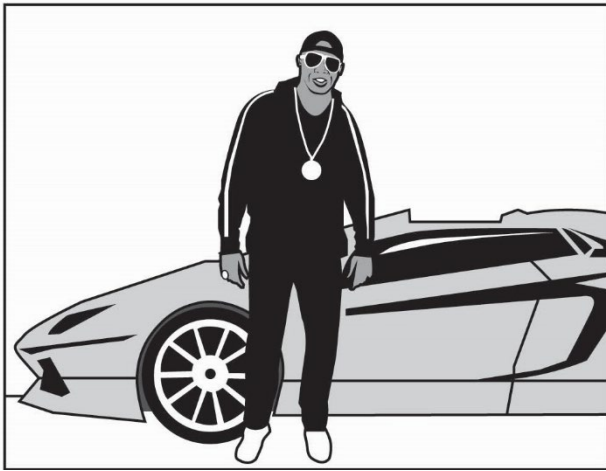

A. to be rich

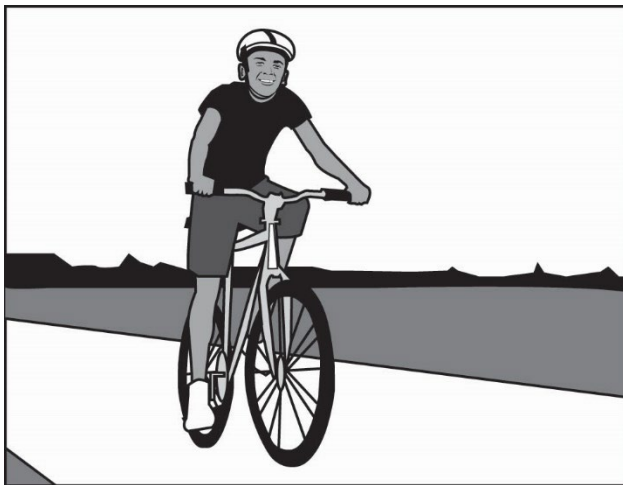

B. to have a bike



C. to laugh at a story

Session 3

Session 3 – Item 25 Answer Options



A. They are all sports.



B. They are all workers.

Session 3 – Item 26 Answer Options

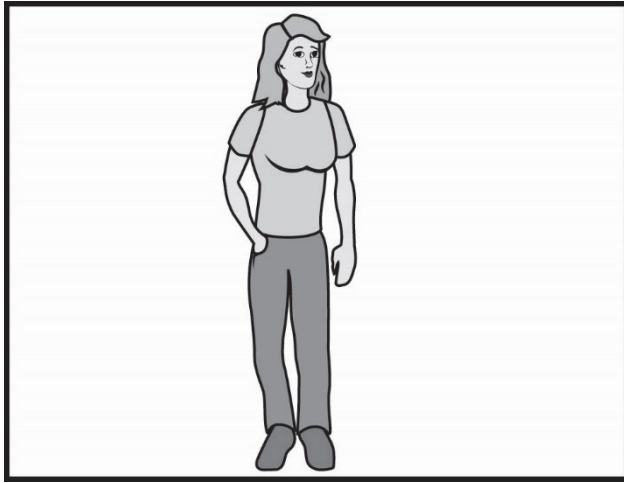

A. My mom is always nice.

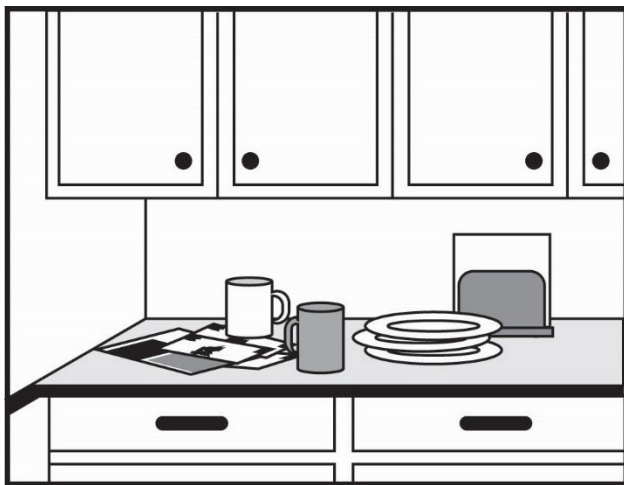

B. The counter has stuff all over it.



C. My painting has many different shapes.

Session 3 – Item 27 Answer Options

A. Bushes and trees have leaves.

B. Bushes are smaller than trees.

C. Bushes and trees grow in soil.

Session 3 – Item 28 Answer Options

A. She saw a deer near her house.

B. She saw a good show on TV last night.

C. She saw tools that were used many years ago.

Writing Stimulus 1, “Janell’s Cake” (Items 29-32)

Janell’s Cake

Janell wants to bake a cake.

Janell asks Grandma, “Can I bake a cake?” Grandma says, “You can make a cake for Grandpa.”

Janell makes a cake with pink icing.

When Grandpa sees the cake, he tastes it and smiles.

Session 3 – Item 29 Answer Options

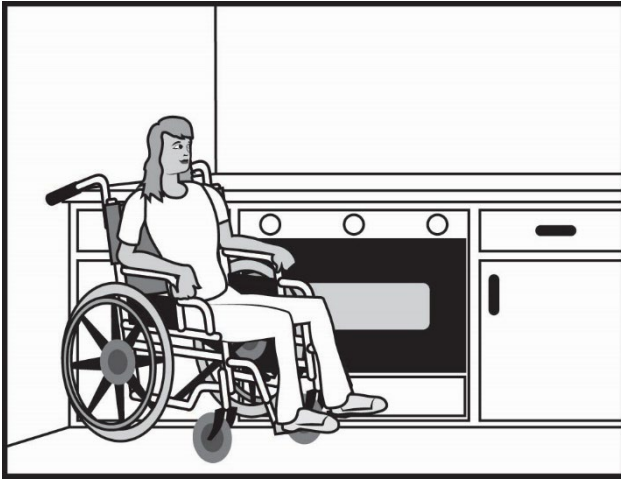

A. Janell wants to bake a cake.

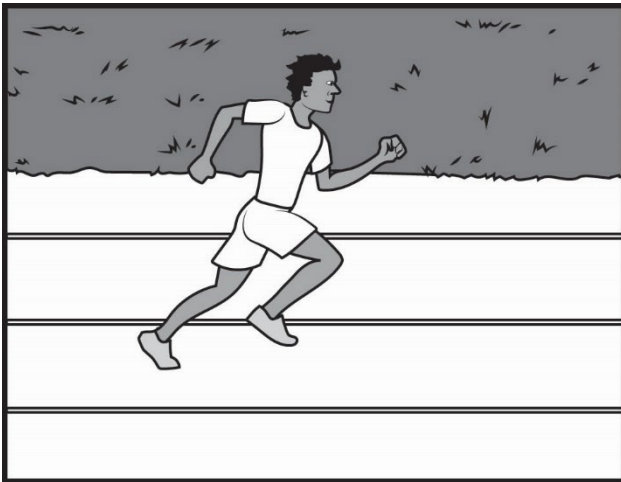

B. Some people run very fast.

Session 3 – Item 30 Answer Options



- A. Janell asked Grandma, "Can I go outside and play?" Grandma says, "Yes."

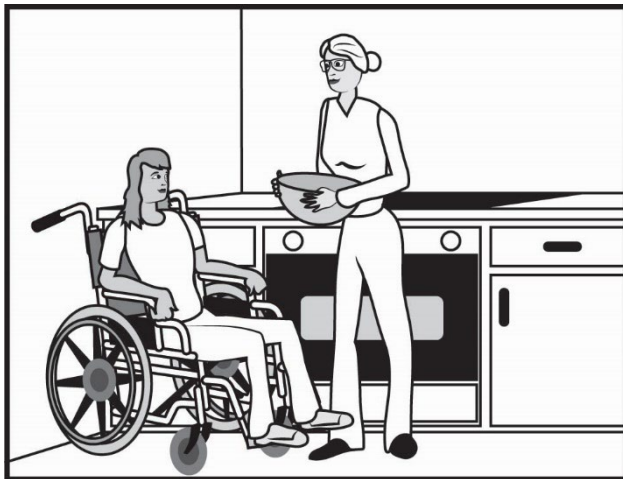

- B. Janell asks Grandma, "Can I bake a cake?" Grandma says, "You can make a cake for Grandpa."

Session 3 – Item 31 Answer Options

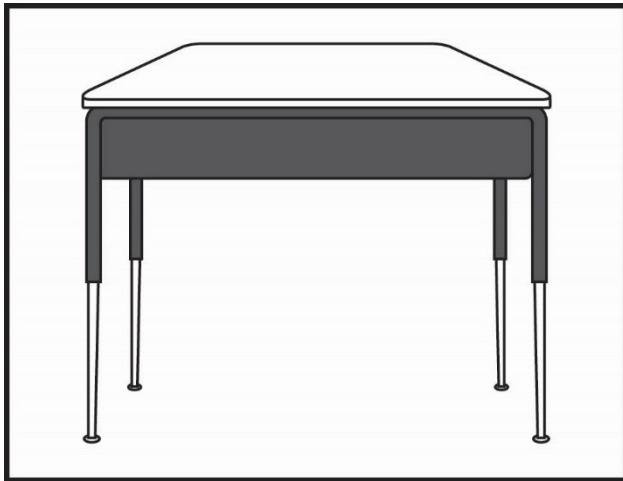

A. The desk at school was clean.



B. Janell makes a cake with pink icing.

Session 3 – Item 32 Answer Options

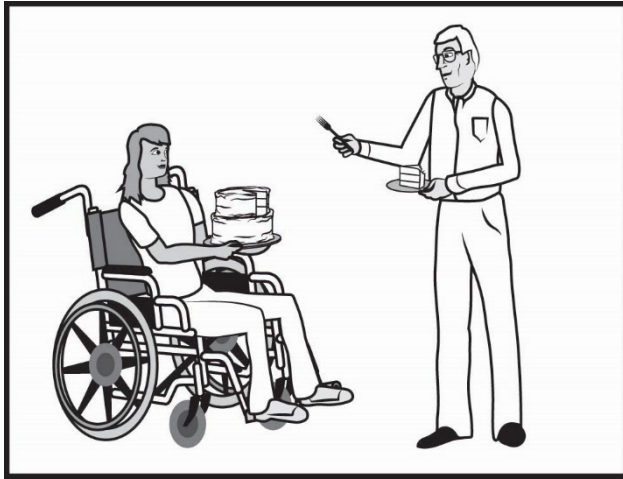

- A. When Grandpa sees the cake, he tastes it and smiles.

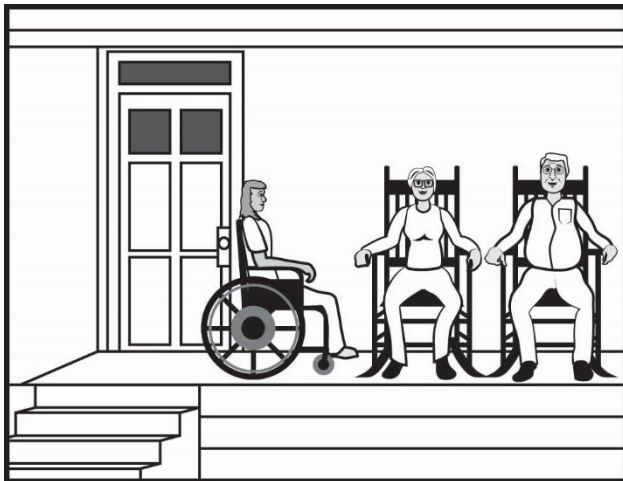

- B. Janell and her grandparents sat on the porch.

Session 4

Grade 5 Stimulus Materials List: Writing Stimulus 2: “Easy to Be Kind”

Card 1a: Easy to Be Kind

Card 2a: 3 Illustrations of “Easy to Be Kind”

Card 3a: Me

Card 4a: Someone else

Card 5a: Blank main character card

Card 6a: Blank other character card

Card 7a: Blank being kind to someone card

Card 8a: Capital letters, end punctuation, and complete sentences

Card 9a – 10a: Response template

Easy to Be Kind

¹One day, Charlie is at home with his sister, Sara. Sara is sad because she has broken her ankle. Charlie is kind by deciding to cheer her up.

First, Charlie makes them lunch. Charlie and Sara eat tasty sandwiches and crunchy apple slices.

²Then, Charlie asks Sara if she wants to play a game. “Let’s play cards. We can play Go Fish,” says Sara. They have fun playing together.

³Finally, Charlie and Sara watch a movie. Sara feels better after Charlie plays with her all day.

Easy to Be Kind Card 1a - **Must be securely destroyed after testing.**

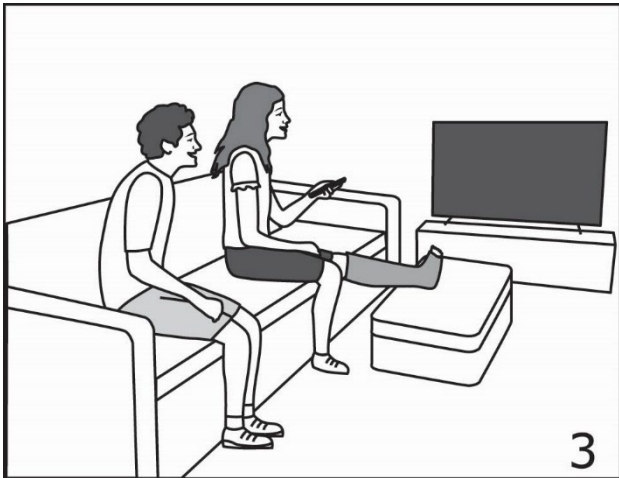
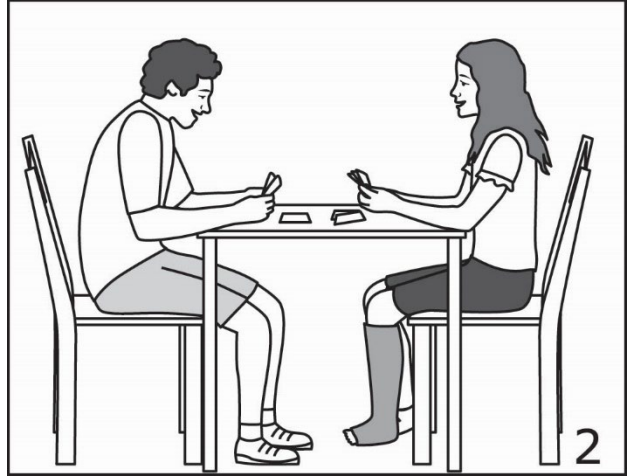
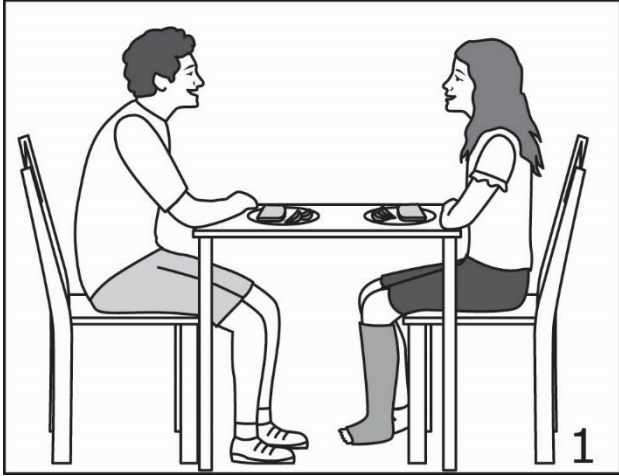

Easy to Be Kind Card 2a - **Must be securely destroyed after testing.**

Me

Easy to Be Kind Card 3a - **Must be securely destroyed after testing**

Someone else

Easy to Be Kind 4a - **Must be securely destroyed after testing.**



Easy to Be Kind Card 5a - **Must be securely destroyed after testing**



Easy to Be Kind Card 6a - **Must be securely destroyed after testing**



Easy to Be Kind Card 7a - **Must be securely destroyed after testing**



Card intentionally left blank

B b E e

. ! ?

Good writers use complete sentences.

Topic: Being Kind to Someone

One day _____ is

_____ is kind to

_____ by

First, _____

Then, _____

_____ says, “ _____

”

Finally, _____

Easy to Be Kind Card 9a – 10a - **Must be securely destroyed after testing**

LEAP CONNECT

Practice Test