

Activity Page 1.1**Use with Chapter 1****Letter to Family**

During the next few weeks, as part of our study of the Bayou Bridges Curriculum Series, your child will be learning about the European Renaissance, Reformation, and Scientific Revolution. They will learn about the events that shaped Europe from 1300 to 1650 CE.

In this unit, students will study the geography of the Italian city-states and Western Europe; learn about influential artists such as Leonardo da Vinci and Michelangelo; study the writings of Niccolò Machiavelli; explore the causes and effects of the Protestant Reformation across Europe; differentiate between the geocentric and heliocentric theories of the solar system; compare Bacon's and Descartes's scientific methods; analyze primary sources; and evaluate claims and evidence.

As part of their exploration, students will also learn about Catholicism and Protestantism. This information is presented in a factual, age-appropriate way rather than in a manner that suggests the value or correctness of any particular culture or group. The goal is to foster understanding of and respect for people and communities that may be different from those with which students are familiar.

Sometimes students have questions regarding how the information they are learning relates to themselves and their own experiences. In such instances, we will encourage each student to discuss such topics with you. We recognize that the best place to find answers to those types of questions is with your family and the adults at home.

Please let us know if you have any questions.

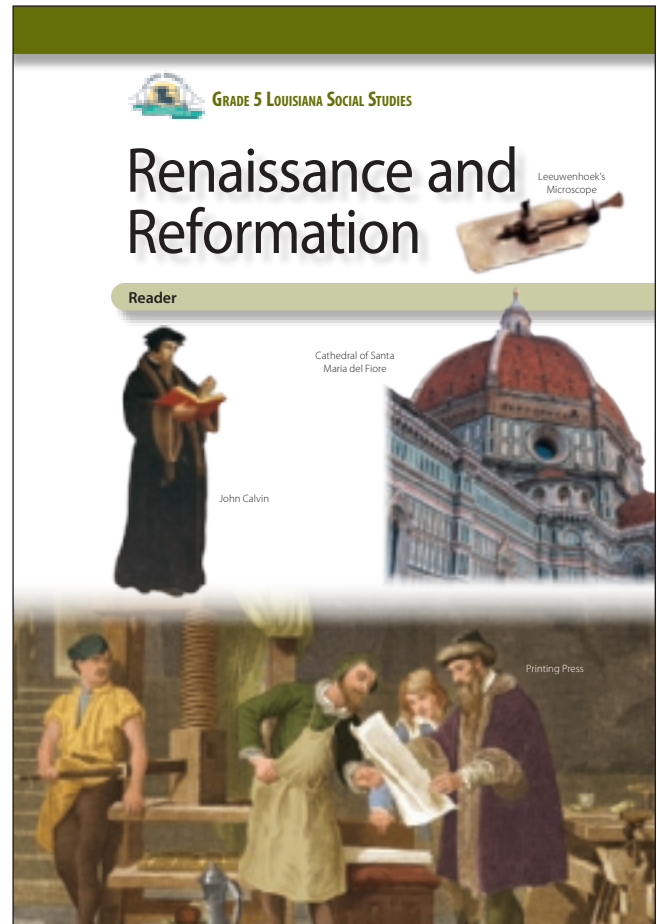

Name _____ Date _____

Primary Source Analysis

<p>Describe the source.</p>	<p>Connect the source to what you know.</p>
<p>Understand the source. Identify its purpose, message, and/or audience.</p>	<p>Draw a conclusion from or about the source.</p>

SOURCE:

Name _____ Date _____

Primary Source Analysis

<p>Describe the source.</p>	<p>Connect the source to what you know.</p>
<p>Understand the source. Identify its purpose, message, and/or audience.</p>	<p>Draw a conclusion from or about the source.</p>

SOURCE:

Name _____ Date _____

Primary Source Analysis

<p>Describe the source.</p>	<p>Connect the source to what you know.</p>
<p>Understand the source. Identify its purpose, message, and/or audience.</p>	<p>Draw a conclusion from or about the source.</p>

SOURCE:

Name _____ Date _____

Primary Source Analysis

<p>Describe the source.</p>	<p>Connect the source to what you know.</p>
<p>Understand the source. Identify its purpose, message, and/or audience.</p>	<p>Draw a conclusion from or about the source.</p>

SOURCE:

Name _____ Date _____

Primary Source Analysis

<p>Describe the source.</p>	<p>Connect the source to what you know.</p>
<p>Understand the source. Identify its purpose, message, and/or audience.</p>	<p>Draw a conclusion from or about the source.</p>

SOURCE:

Name _____ Date _____

Primary Source Analysis

<p>Describe the source.</p>	<p>Connect the source to what you know.</p>
<p>Understand the source. Identify its purpose, message, and/or audience.</p>	<p>Draw a conclusion from or about the source.</p>

SOURCE:

Name _____ Date _____

Primary Source Analysis

<p>Describe the source.</p>	<p>Connect the source to what you know.</p>
<p>Understand the source. Identify its purpose, message, and/or audience.</p>	<p>Draw a conclusion from or about the source.</p>

SOURCE:

Activity Page 1.3

Use with Chapter 2 and Performance Task

Claims and Evidence

STATE THE CLAIM *What opinion or position are you defending?*

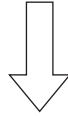

STATE THE REASON *Why should someone agree with this claim?*

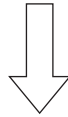

IDENTIFY THE EVIDENCE *What details from the text and sources support the reason?*

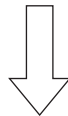

RECOGNIZE A COUNTERCLAIM *What different opinion or position might someone have?
What argument might be used against you?*

ANSWER THE COUNTERCLAIM *How will you disprove the counterclaim?*

Name _____

Date _____

Activity Page 1.4

Use with Chapter 1

Map of Renaissance Italy

Study the map. Use it to answer the questions below.

The Italian Peninsula in the Renaissance



1. Which three Italian cities are located on the coast, making them suitable for trade by sea?

2. Which island is south of the Italian peninsula?

3. Which city on the map is farthest north?

4. Which city on the map is located along the Adriatic Sea?

5. In which area or territory is the city of Rome located?

6. What two islands are located in the Tyrrhenian Sea?

7. Approximately how far is Florence from Rome?

8. Which is farther from Florence: Milan or Naples?

Activity Page 1.5

Use with Chapter 1

Linear Perspective

Directions: Follow the instructions below to create your own drawing using linear perspective.

1. Make a dot at the approximate center of a sheet of paper. This dot is called the *vanishing point*.

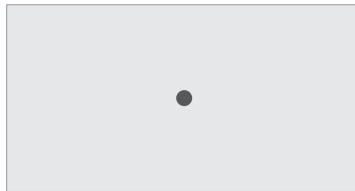

2. Use a ruler to draw a horizontal line through the vanishing point. The line should be parallel to the bottom of the paper. This is called the *horizon line*.

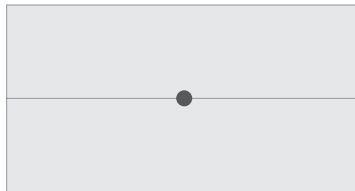

3. Using a ruler, draw two diagonal lines that cross at the vanishing point. These lines are called *orthogonal lines*.

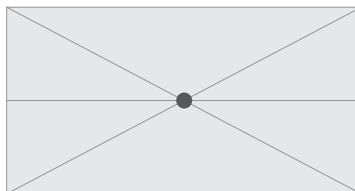

4. In the space between the orthogonal lines on each side of the vanishing point, draw trees or buildings. Make sure each tree or building touches both the top and bottom orthogonal lines. The closer the trees or buildings are to the vanishing point, the smaller they will be.
5. Fill in your drawing with people, cars, animals, or other things. Use the trees or buildings as a guide for how small or big the other things should be.

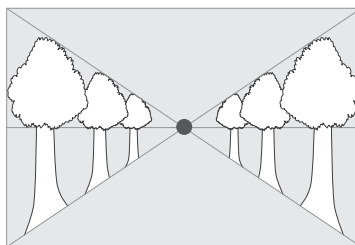

Activity Page 3.1

Use with Chapter 3

Galileo's Trial

Part 1: Planning

1. My group is _____
2. What arguments does your group plan to make?
3. What arguments will the other side likely make? How can you respond to those arguments?

The Other Side's Arguments	Our Response

Part 2: Reflection After the Arguments

1. What were the strengths of Galileo's group's argument?
2. What were the weaknesses of Galileo's group's argument?
3. What were the strengths of the argument by the Church officials' group?
4. What were the weaknesses of the argument by the Church officials' group?
5. Which group was more convincing? Why?
6. In history, which group won at Galileo's trial? Why did it win?

Name _____

Date _____

Activity Page 3.2

Use with Chapter 3

Domain Vocabulary: Chapters 1–3

Use the words in the word bank to complete the crossword puzzle.

Baroque	classical	credit	dissection	fresco
doge	exemplify	geocentric	geometry	heliocentric
heretic	indulgence	monastery	patron	perspective
pope	predestination	purge	rational	
reformer	secular	skepticism	theology	
	thesis	university		

Across:

1. to be an example of
4. relating to a style of European art popular in the seventeenth and eighteenth centuries
8. describing the sun as the center of the universe
9. the act of cutting something into parts in order to study it
12. the removal or reduction of certain punishments for sin, linked to a special act of penance
14. an idea or opinion
15. describing Earth as the center of the universe
17. a person who goes against the accepted teachings of a religion
20. a person who challenges existing ideas in an institution
21. the head of government of the city of Venice
22. based on reason and logic
24. the study of religious faith, practice, and experience
25. a removal from a group or place in a sudden or violent way

Down:

2. the idea that a person's salvation has already been decided by God
3. a person who gives money or other support to someone, such as an artist
5. a school where advanced learning is taught
6. a method of looking at information and evidence through questioning and doubt
7. an art technique used to make something that is flat appear to have depth, in addition to height and width
10. a building where a community of monks lives, worships, and works together
11. a type of wall painting made on wet plaster
13. a branch of mathematics that studies the measurements and relationships between lines, angles, surfaces, and shapes
16. relating to the literature, art, architecture, or ideas of the ancient Greek and Roman world
18. a system of buying now and paying later based on a person's honesty and ability to pay
19. the head of the Roman Catholic Church
23. not religious or faith based

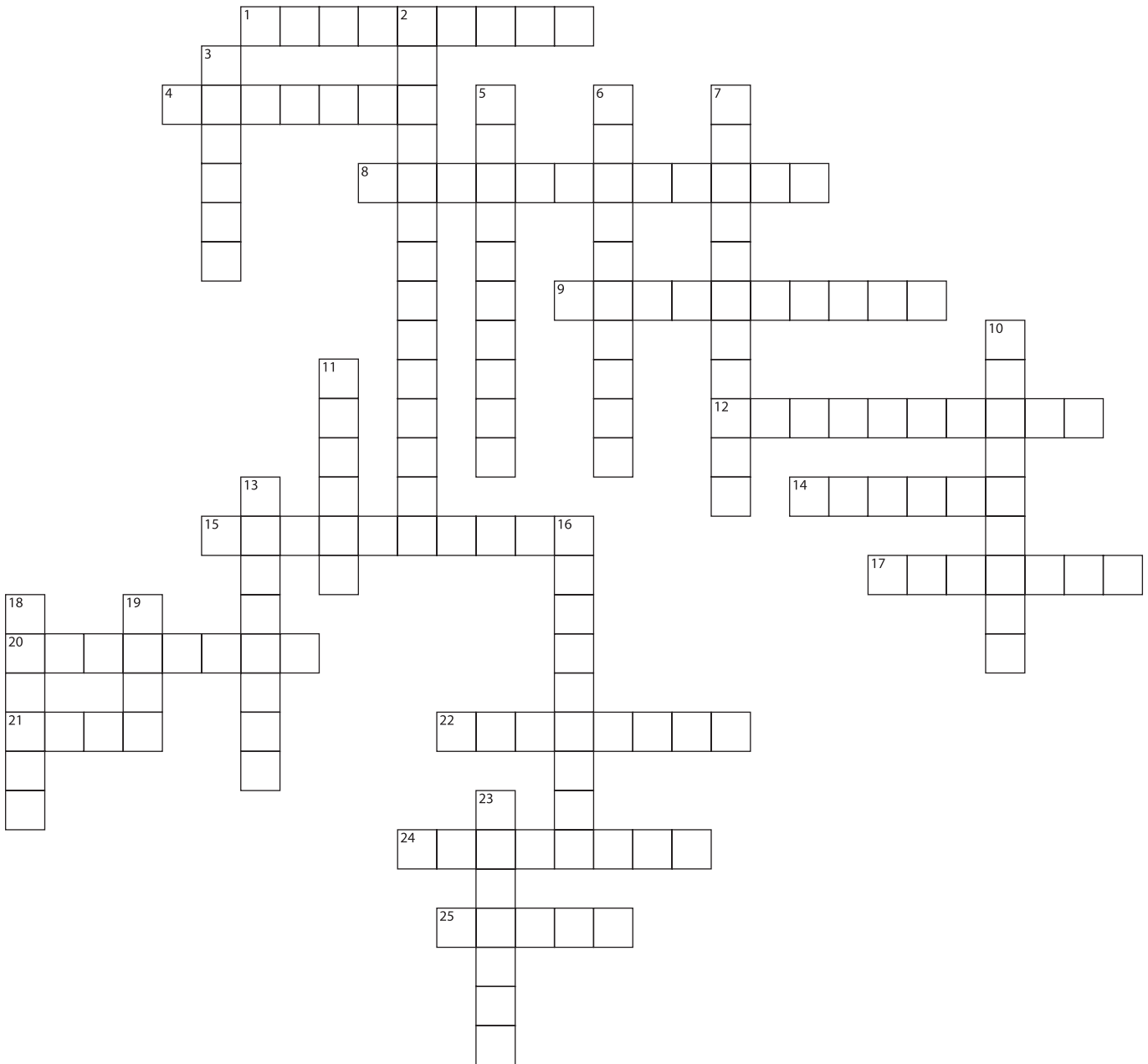

Assessment: Chapter 1—*The Renaissance*

A. On your own paper, write the letter that provides the best answer.

1. Which statement best describes the Renaissance? (5.12)
 - a) an era of war and tyranny
 - b) an age in which learning was lost
 - c) the revival of religious faith
 - d) the rebirth of art and learning

Use the map to answer questions 2 and 3.



2. Which major city-state was closest to Venice? (5.6)
 - a) Sicily
 - b) Rome
 - c) Sardinia
 - d) Bologna
3. Which statement best explains a reason why the Renaissance flourished in Italy? (5.12)
 - a) Rulers in Italy rejected the teachings of the Church.
 - b) Humanism was banned in most of Europe.
 - c) Holy Roman Emperors encouraged new ideas.
 - d) Wealthy citizens and the Church supported artists and architects.

4. Which are humanist ideals? Select the **two** correct answers. (5.12)

- a) striving for eternal salvation
- b) understanding the spiritual world
- c) celebrating the human experience
- d) recognizing the potential within each person
- e) allowing humans to shape religious rules
- f) spiritual harmony between humans and nature

Use the image to answer questions 5 and 6.



5. Who created this painting? (5.2.a, 5.12, 5.12.c)

- a) Leonardo da Vinci
- b) Filippo Brunelleschi
- c) Leon Battista Alberti
- d) Michelangelo Buonarroti

6. What technique was used to create the illusion of depth in this painting? (5.2.a, 5.12, 5.12.c)

- a) fresco
- b) plaster
- c) movable type
- d) linear perspective

Use the image to answer questions 7 and 8.



7. What type of images are painted on the ceiling in this work of art? (5.2.a, 5.12, 5.12.c)
 - a) images depicting world events
 - b) images depicting Renaissance events
 - c) images depicting biblical events
 - d) images depicting Roman events
8. Where is this work of art located? (5.12, 5.12.c)
 - a) the Medici family's home in Florence
 - b) the Sistine Chapel, built as a private chapel for the pope in Rome
 - c) the Cathedral of Santa Maria del Fiore in Florence
 - d) the pope's residence in Avignon, France
9. Use the image to answer the question.

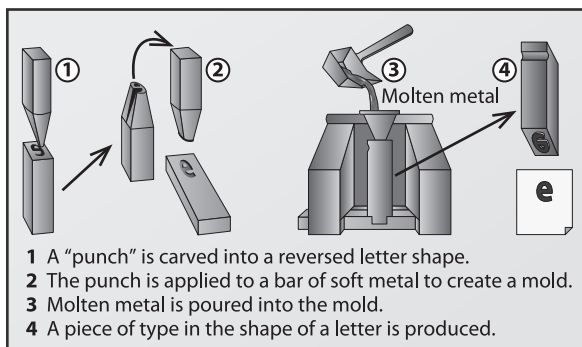

In what ways did Gutenberg's printing press influence the Protestant Reformation? Select the **two** correct answers. (5.2.a, 5.12.d)

- a) Pamphlets and books spreading Protestant ideas were cheaper to make.
- b) Printed texts were easier to hide from Church authorities.
- c) Printed books encouraged the growth of literacy.
- d) Printing presses were easy to construct and maintain.
- e) The specialized knowledge needed to use a press encouraged people to question the Church.

10. Use the following passage from *The Prince* to answer the question:

"But we now come to the case where a citizen becomes prince not through crime or intolerable violence, but by the favor of his fellow-citizens. . . . To arrive at this position depends not entirely on worth or entirely on fortune, but rather on cunning assisted by fortune. One attains it by help of popular favor or by the favor of the aristocracy. For in every city these two opposite parties are to be found, arising from the desire of the populace to avoid the oppression of the great, and the desire of the great to command and oppress the people."

Which phrase from the passage describes what a citizen needs to have in order to become a prince? (5.2.a)

- a) "crime or intolerable violence"
- b) "worth or entirely on fortune"
- c) "cunning assisted by fortune"
- d) "oppression of the great"

B. **On your own paper, write a well-organized paragraph in response to the following prompt:**

Explain one factor that influenced the Renaissance, and explain one way that the Renaissance affected Europe. (5.5, 5.5.a, 5.5.c, 5.5.d, 5.8, 5.12, 5.12.c)

Assessment: Chapter 2—The Reformation

A. On your own paper, write the letter that provides the best answer.

1. Use the maps to answer the question.

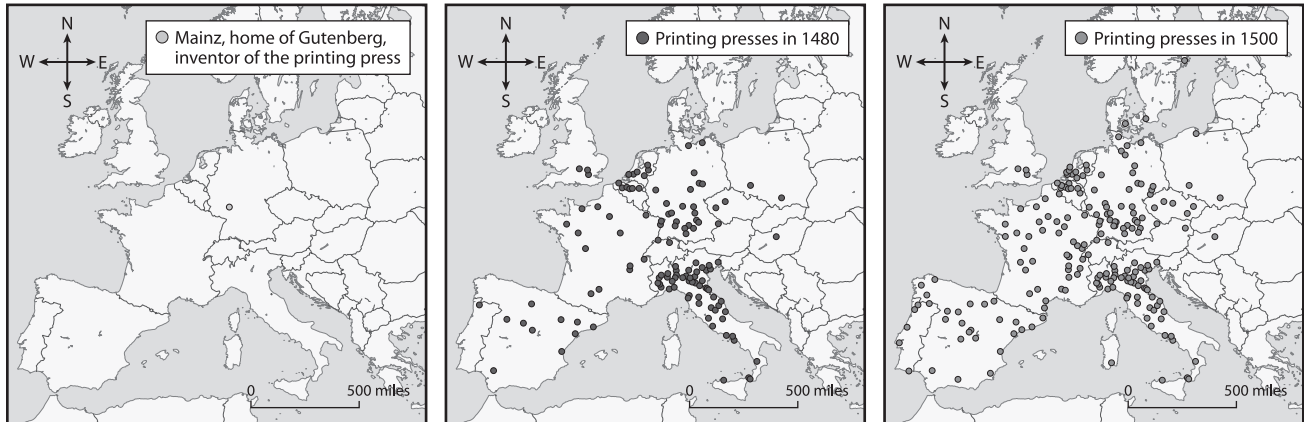

What spread because of the development shown on the map? (5.6, 5.7, 5.12.d)

- a) trade
- b) ideas
- c) slavery
- d) disease

Use the image to answer questions 2 and 3.



2. What prompted Martin Luther to take the action shown in the image? **(5.12, 5.12.e)**
 - a) He was against the pope's return to Rome.
 - b) He wanted to share his theory of predestination.
 - c) He disagreed with the Church's sale of indulgences.
 - d) He thought only clergy should teach Church doctrine.

3. What was an effect of Luther's action shown in the image? **(5.3, 5.8, 5.12, 5.12.e)**
 - a) The Church split into the Catholic Church and the Protestant Church.
 - b) The Catholic Church lowered the prices of indulgences.
 - c) Spain purged all non-Catholics from the country.
 - d) Martin Luther was executed for being a heretic.

4. On which theological ideas did Luther and John Calvin agree? Select the **two** correct answers. **(5.8, 5.12)**
 - a) A person can be saved by faith alone.
 - b) A person does not need religion to be saved.
 - c) A person's fate is decided by God ahead of time.
 - d) A person's actions do not determine the goodness of their soul.
 - e) A person needs only the Bible, not guidance from religious leaders.

5. What was one outcome of the Treaty of Westphalia? (5.3)
- a) Protestantism became the official European religion.
 - b) The Holy Roman Empire expanded its territory.
 - c) Countries were allowed to govern themselves
 - d) Continent-wide rules for governance were set.
6. Use the image to answer the question.



- Why did the person in the image leave the Catholic Church? (5.3, 5.12)
- a) He did not support the sale of indulgences.
 - b) He thought clergy were unnecessary for worship.
 - c) His new wife was a follower of Lutheran doctrine.
 - d) The pope would not allow him to divorce his wife.
7. What did supporters of the Counter-Reformation want the Catholic Church to do in response to the Reformation? Select the **three** correct answers. (5.8, 5.12, 5.12.e)
- a) allow people to leave the Church if they wanted
 - b) provide better education for priests
 - c) establish new schools and universities
 - d) fight corruption within the Church
 - e) adopt translated versions of the Bible

Use the map to answer questions 8 and 9.



8. What was the dominant religion of Spain in the mid-1500s? (5.6, 5.8)
- a) Islam
 - b) Calvinism
 - c) Catholic
 - d) Lutheran
9. Which country was primarily a Calvinist country? (5.6, 5.8)
- a) Netherlands
 - b) Germany
 - c) Denmark
 - d) Spain

10. Use the following excerpt from the ninety-five theses to answer the question:

21. Thus those preachers of indulgences are in error who say that, by the indulgences of the Pope, a man is loosed and saved from all punishment.
27. They preach man [man-made doctrine], who say that the soul flies out of purgatory as soon as the money thrown into the chest rattles.
28. It is certain that, when the money rattles in the chest, avarice [greed] and gain may be increased, but the suffrage [answered prayers] of the Church depends on the will of God alone.
32. Those who believe that through letters of pardon [indulgences], they are made sure of their own salvation, will be eternally damned along with their teachers.

Which thesis describes the consequence for purchasing an indulgence? (5.2.a, 5.12.e)

- a) #21
- b) #27
- c) #28
- d) #32

B. On your own paper, write a well-organized paragraph in response to the following prompt:

The Protestant Reformation would not have happened were it not for the invention of the printing press.

Use evidence from the chapter to support or refute this claim. (5.5, 5.5.c, 5.5.d, 5.8, 5.12, 5.12.d, 5.12.e)

Assessment: Chapter 3—The Scientific Revolution

A. On your own paper, write the letter that provides the best answer.

Use the image to answer questions 1 and 2.

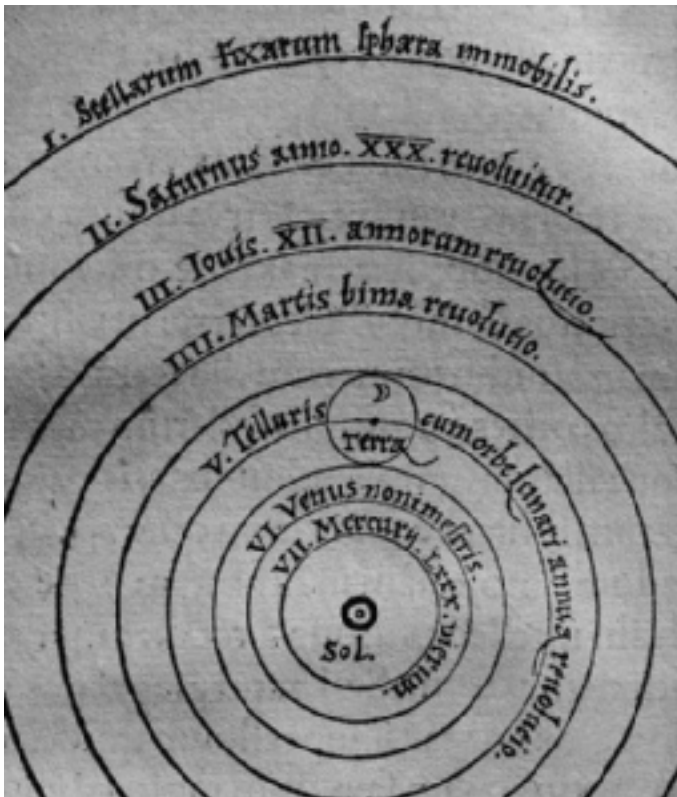

1. Which idea is explained by this diagram? (5.12.f)
 - a) the origin of life
 - b) the distance to Rome
 - c) the anatomy of a human
 - d) the theory developed by Copernicus
2. What does the circle at the center of the diagram represent? (5.12.f)
 - a) the sun
 - b) Earth
 - c) the moon
 - d) the Milky Way
3. Which statement best explains why the Roman Catholic Church rejected Galileo's scientific discoveries? (5.12.f)
 - a) Church leaders feared that Galileo's discoveries would make people convert to other religions.
 - b) Church leaders feared the rise of new technology.
 - c) Church leaders felt that Galileo's discoveries went against the Bible's teachings.
 - d) Church leaders were concerned that Galileo was becoming too powerful.

4. Which phrases best describe Renaissance ideas that influenced the Scientific Revolution? Select the **two** correct answers. (5.12)
- a) encouraging curiosity
 - b) focusing on spirituality
 - c) maintaining traditions
 - d) defending rights
 - e) exploring new lands

Use the chart to answer questions 5, 6, and 7.

Scientist	Discovery
Harvey	A
Galileo	B
C	Bacteria
D	laws of motion

5. Which discovery belongs in Box A? (5.12)
- a) how to heal wounds faster
 - b) how muscles are structured
 - c) how blood pumps through the body
 - d) how oxygen moves around the body
6. Which discoveries could go in Box B? Select the **two** correct answers. (5.12.g)
- a) Jupiter's moons
 - b) the existence of gravity
 - c) the compound microscope
 - d) the invention of movable type
 - e) Earth's moon's mountains and valleys
7. Who belongs in Box D? (5.12)
- a) Tycho Brahe
 - b) Isaac Newton
 - c) Francis Bacon
 - d) René Descartes
8. Which phrases best describe parts of Francis Bacon's scientific method? Select the **two** correct answers. (5.12)
- a) relying on traditional ideas
 - b) using math to understand the universe
 - c) observing things in nature
 - d) using science to solve real-life problems
 - e) making predictions without observation

9. How did Isaac Newton develop his scientific method? (5.12)
- a) He combined the ideas of Descartes and Bacon.
 - b) He used the existing methods of Galileo and Copernicus.
 - c) He created a method based on instinct and repeatable tests.
 - d) He followed the Church's teachings about the presence of God in all things.
10. Use the following passage from "Excerpt from Galileo's Letter to Grand Duchess Christina of Tuscany (1615)" to answer the question.

"To command professors of astronomy that they must themselves see to confuting [arguing against] their own observations and demonstrations is to ask the impossible, for it is not only to command them not to see what they do see, and not understand what they do understand, but to seek for and to find the contrary. . . .

. . . it is not in the power of any creature to make them to be true or false, otherwise than as, in fact, they are."

Which statement summarizes Galileo's argument? (5.2.a, 5.12.g)

- a) "You cannot ask a scientist to teach something they know to be false."
 - b) "We don't see or understand impossible things, so we can't teach them."
 - c) "Things that can be observed and demonstrated are true; everything else is false."
 - d) "Humans cannot change facts, so there's no use in trying to change how we teach them."
- B. On your own paper, write a well-organized paragraph in response to the following prompt:**

Explain one cause of the Scientific Revolution, and explain one effect of the Scientific Revolution. (5.2.a, 5.2.b, 5.3, 5.4, 5.5.a, 5.5.b, 5.5.c, 5.12, 5.12.f, 5.12.g)

